

BrainChild



BPC01

Thyristor Power Regulator

Product features

- ❑ Independent adjustment of Max and BIAS.
- ❑ Down-opened Panel, easy for fuse replacement.
- ❑ VR of Max and SFS are installed in the front panel, easy for adjustment.
- ❑ Multi-LED display panel makes the operating condition clear.
- ❑ The auxiliary powers (AC1, AC2) are independently controlled for all models.
- ❑ Build-in buffering output adjustment (SFS VR), adjusting range 1~22 seconds. (Only for the phase control product)
- ❑ Top & bottom shielding covers are designed for safety and fashion out looking, also easy for wiring installation.
- ❑ In case of 0.5 Hz sudden power losses, system output can be switched off immediately. Once the power is restored, the system will buffer the output to prevent the voltage surge for fuse burn-down.
- ❑ Main power is one spec. Design for 200~480VAC.
- ❑ Automatic power frequency detection for 50~60 Hz. No need for selection or switch.
- ❑ Automatic detection and display for power out-of-phase, BPC01 overheating, and fuse burn-down with one set of alarm dry contact output.
- ❑ In cases of BPC01 overheating or fuse burn-down, the system output is stopped immediately. Once the malfunction is eliminated and power is restored, the system will buffer the output to prevent the fuse burn-down.
- ❑ 4~20mA, 1~5VDC, 2~10VDC, 0~20mA, 0~5 VDC, 0~10VDC, dry contact points, etc. and all control signals are ready to use.
- ❑ Triggering circuit and the main board are designed separately to avoid the main board damage when main circuit malfunctions.
- ❑ Using European detachable control signal connector for easy replacement without re-wiring installation.



Outline descriptions

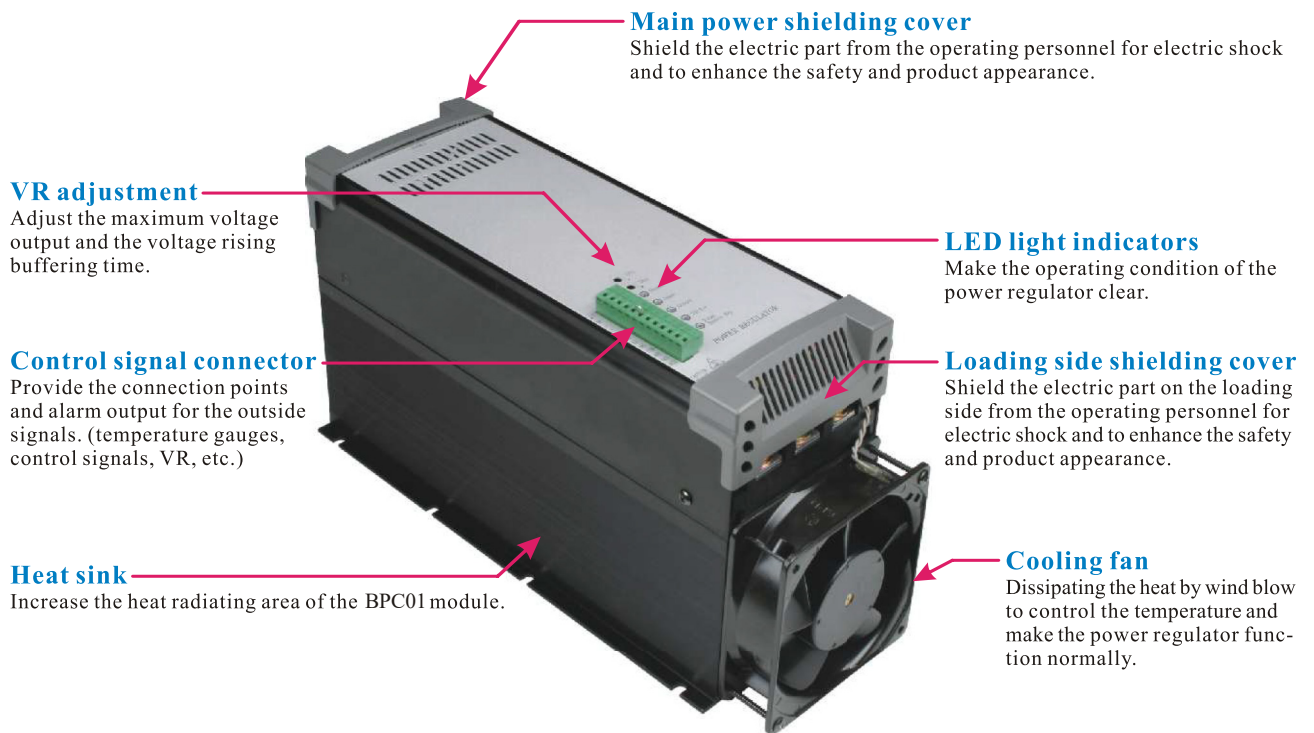

Installation and ambient conditions

- ❑ When the power regulator is operating, the heat will be generated automatically. Please install the system vertically and leave some empty space on two sides to avoid the temperature inside the regulator rising continuously.
- ❑ When the product installs, the base must attach the mounting plates, in order to enhance cooling cycle.
- ❑ There must be some ventilation holes on the control box. Please follow the principle of hard air rising to install the ventilation holes or extra cooling fans.
- ❑ Please avoid installing the regulator in the place with high temperature or poor ventilation. Otherwise, the maximum operating capacity must be set lower than 70% of the nominal capacity.
- ❑ Avoid installing the regulator in the places with heavy water evaporation, acid, alkaline, or corrosive air.
- ❑ Ambient humidity: below 90%RH (no condensation)
- ❑ Ambient temperature: -10°C~45°C

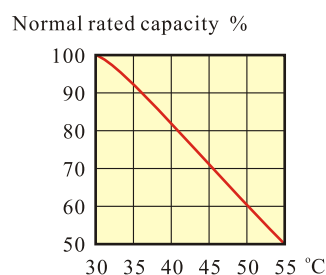

※ The above numbers are based on the conditions of no erosion, no greasy dirt, and no cover on the heat sink and following the recommended installation guides based on the principle of heat transfer.



Control and applied loading

Control mode \ Output	Output wave		
	10% Output	50% Output	90% Output
Phase angle control			
Zero crossing control	 1 cycle ON and 9 cycle OFF	 1 cycle ON and 1 cycle OFF	 9 cycle ON and 1 cycle OFF

- Phase angle control: continuous phase angle control, steady output, current gauge reading remains steady.
But, every half wave will produce harmonic wave.
Applicable loading: fixed resistance loading, variable resistance loading, inductive loading, IR light bulb.
- Zero crossing control: distributed zero crossing control, minimum resolution 1 Hz, no harmonic wave, and current gauge reading oscillates.
Applicable loading: fixed resistance loading.

Wiring and setup notices

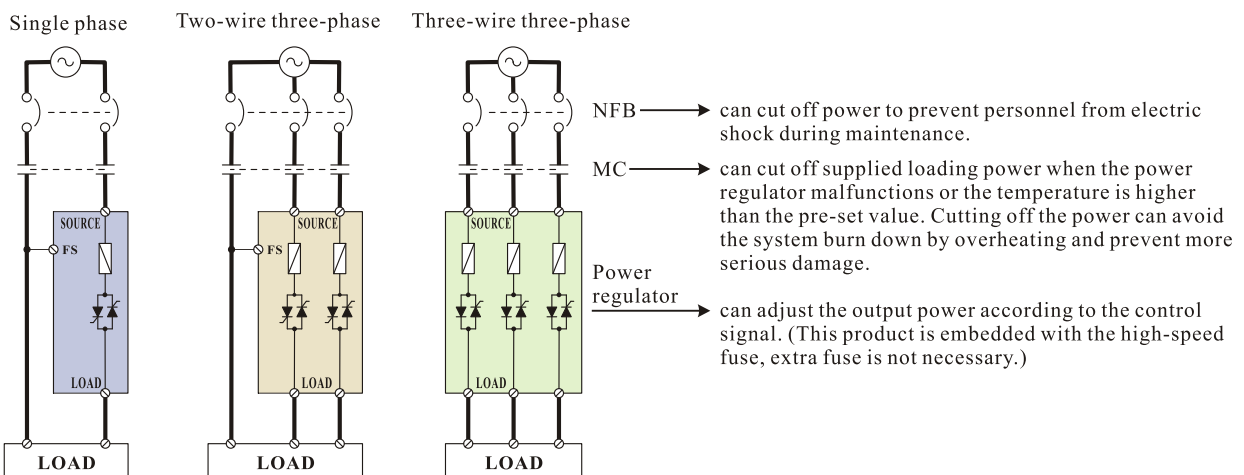

- Standard main circuit setup: main power → molded case circuit breaker → contactors → power regulator → loading.
- The screw must be tightened during the wiring setup to avoid high temperature resulting from bad contact.
- Once the wiring setup is completed, the front panel and safety cover must be properly installed before the system is powered up to avoid the electric shock or short circuit caused by dropped conductive objects.

Ordering Code

Product series	BPC01	BPC01 series	
Control	SP	Single-phase angle control	
	SZ	Single-phase zero crossing control	
	TP	Three-wire three-phase angle control	
	TN	Four-wire three-phase angle control (Loads with Y connection, neutral point connection N)	
	TZ	Two-wire three-phase zero crossing control	
	ZZ	Three-wire three-phase zero crossing control	
Main power voltage	1V	50~120VAC	
	4V	200~480VAC	
Normal rated current	030	30A	
	045	45A	
	060	60A	
	080	80A	
	100	100A	
	125	125A	
	150	150A	
	180	180A	
	230	230A	
	300	300A	
	380	380A	
	450	450A	
580	580A		
720	720A		
Dash	-		
Auxiliary power source code	1	1φ 110VAC	
	2	1φ 220VAC	
Input signal code	0	0~5VDC	
	1	1~5VDC	
	2	2~10VDC	
	3	0~10VDC	
	4	4~20mA	
	5	0~20mA	
	M	Manual adjustment	
*	Special		
Buffering time code	C	Not have Buffering time (Zero-crossing type of product)	
	J	Adjustable buffering time, 1~22 seconds (Phase-angle type of product)	
Special code	00	None	
	TF	Inductive reactance type of loading	
	CV	Constant voltage type	
	CL	Limited current type (RMS limited current value cannot adjust)	
	L/C	Limited current type (RMS limited current value can adjust)	
	C/L	Constant current type (RMS constant current value can adjust)	
		Only for phase-angle type of product	

Standard type

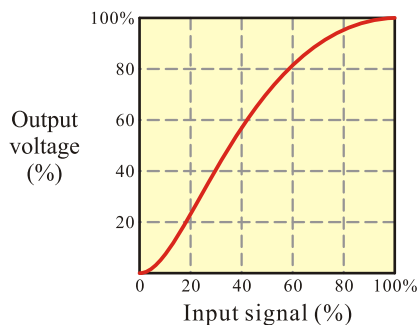

Constant voltage type

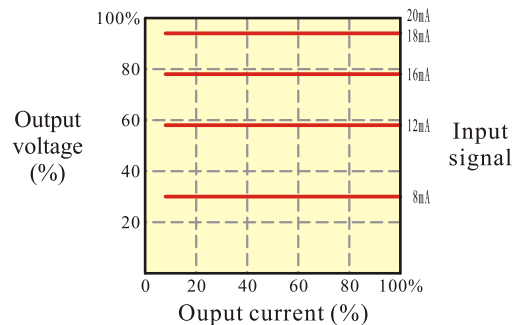

Limited Current type

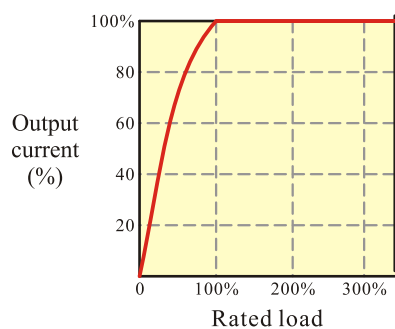

Constant current type

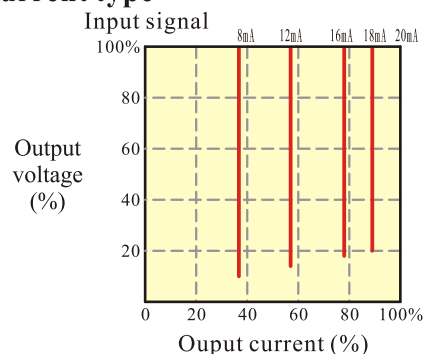

Selection of the input signal



- Ⓒ 4~20mA · 0~20mA · MANUAL Selection S1 (Input impedance 249Ω)
- Ⓒ 1~5VDC · 0~5VDC Selection S2 (Input impedance 200KΩ)
- Ⓒ 2~10VDC · 0~10VDC Selection S3 (Input impedance 18KΩ)

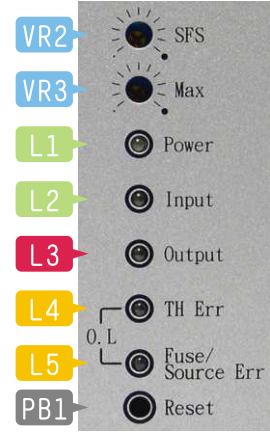
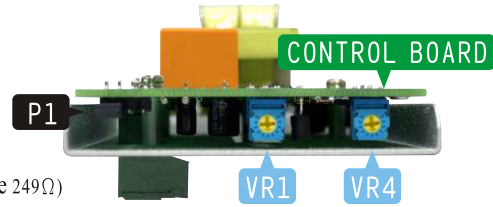

Functional adjustment

- VR1 BIAS** : Adjustment of standard output voltage.
(Counter-clockwise adjust the control signal, lower the input will produce the output.)
- VR2 SFS** : Adjustment of buffer rising time.
(Adjusting range 1~22 seconds, clockwise adjustment will increase the time. No applicable for zero crossing type product.)
Limited current type/Constant current type : Adjusting range 2~16 seconds.
- VR3 Max** : Adjustment of maximum output voltage.
(Adjusting range 0~100%, counter-clockwise adjustment will decrease the output. Set to zero will have no output.)
Limited current type/Constant current type :Current adjustment.(Adjusting range 50~100%, counter-clockwise adjustment will decrease the output.)
- VR4 OL SET** : Adjustment of Over current.(Adjusting range 60~120%,counter-clockwise adjustment will decrease the output.)
- PB1 RESET** : Over current RESET.

Descriptions for LED lights and trouble shooting

L1 Power Power light	<ul style="list-style-type: none"> On: Auxiliary power on. Off: 1. Auxiliary power sources have no output → make sure AC1, AC2 auxiliary power sources have power output. 2. Control board malfunction → please replace the same spec. control board or send the power regulator for maintenances.
L2 Input Input light	<ul style="list-style-type: none"> On: Control input signal is in. Off: 1. Control signal is not in → please check the temperature gauge to see if there is input, check the connection and the wiring. 2. Wrong connection on the electrodes of the control board → check the electrodes of the temperature gauge. 3. Set to zero on the Max VR of the control board or outside VR → check two VRs to see if any one of them is set to zero. 4. Control board malfunction → please replace the same-spec. control board or send the power regulator for Maintenances.
L3 Output Output light	<ul style="list-style-type: none"> On: Power regulator is in output $\left\{ \begin{array}{l} \text{phase angle control. (light and dark based on the output.)} \\ \text{zero crossing control. (flash based on the output.)} \end{array} \right.$ Off: 1. If the abnormal light L5 is on. (fuse burn down or main power has no output.) → please refer to ERR (L5). 2. If the temperature light L4 is on. (power regulator is overheating.) → please refer to TH (L4). 3. If the input light L2 is off. (No input signal.) → please refer to IN (L2). 4. If the input light L2 is on. (control board malfunction.) → please replace the same spec. control board or send the power regulator for maintenances.
L4 TH Err Over heating light	<ul style="list-style-type: none"> On: 1. Power regulator is over heating → cooling fan is not operating, check the power, fan damage, or if the fan is stuck by any object and get rid off it if necessary. 2. Bad ventilation or the ambient temperature is too high → please change the installation place or improve the ventilation. Off: Normal, power regulator is not overheating.
L5 FUSE/ Source Err Power source abnormal light	<ul style="list-style-type: none"> On: 1. Main power source have no output or out-of-phase → check the power output and all the abnormal conditions. 2. High-speed fuse burn down → please replace the same spec. fuse and check the shortage and the ground of the loading before restoring the power. Off: Normal
L4&L5 O.L Over current light	<ul style="list-style-type: none"> L4 and L5 On: Power regulator is over current → please check the shortage and the ground of the loading before press PB1 to reset. (Limited current type/Constant current type of product) Off: Normal

Descriptions of the connectors

Single phase angle, Single phase zero crossing, Two-wire three-phase zero crossing (SP、SZ、TZ)

Connector pin	Connector No.	Description	Notes
TB-01	FS	Detection of the fuse burn down	The connection from power to loading must be connected back to the FS side.
TB-02	M	+5VDC	Only for this control board, not for other use positive control signal input.
TB-03	+	Positive control signal input	The default setting is 4~20mA when the sticker is not marked.
TB-04	—	Standard analog signal voltage	
TB-05	E3	Connected to the VR 3rd pin of the outside potentiometer	Adjustable output 0~100%, Please eliminate the shorted copper wire between E3 and E2 when using the outside potentiometer with VR. (2~10KΩ)
TB-06	E2	Connected to the VR 2nd pin of the outside potentiometer	
TB-07	E1	Connected to the VR 1st pin of the outside potentiometer	
TB-08	NC	Alarm connector output (normal close)	Connector capacity 250VAC 2A. 125VAC 2A. 30VAC 2A.
TB-09	COM	Alarm connector output (common point)	
TB-10	NO	Alarm connector output (normal open)	
TB-11	AC1	Auxiliary power source	Please refer to the stick for the auxiliary power and voltage.
TB-12	AC2		

Three-wire three-phase angle, Three-wire three-phase zero crossing, Four-wire three-phase angle (TP、ZZ、TN)

Connector pin	Connector No.	Description	Notes
TB-01	•	Empty pin	Do not connect.
TB-02	M	+5VDC	Only for this control board, not for other use positive control signal input.
TB-03	+	Positive control signal input	The default setting is 4~20mA when the sticker is not marked.
TB-04	—	Standard analog signal voltage	
TB-05	E3	Connected to the VR 3rd pin of the outside potentiometer	Adjustable output 0~100%, Please eliminate the shorted copper wire between E3 and E2 when using the outside potentiometer with VR. (2~10KΩ)
TB-06	E2	Connected to the VR 2nd pin of the outside potentiometer	
TB-07	E1	Connected to the VR 1st pin of the outside potentiometer	
TB-08	NC	Alarm connector output (normal close)	Connector capacity 250VAC 2A. 125VAC 2A. 30VAC 2A.
TB-09	COM	Alarm connector output (common point)	
TB-10	NO	Alarm connector output (normal open)	
TB-11	AC1	Auxiliary power source	Please refer to the stick for the auxiliary power and voltage.
TB-12	AC2		

Applicable high-speed fuse for the power regulator

Rated current	30A	45A	60A	80A	100A
Fuse	40ET	63ET	80ET 660GH-80	660GH-100	660GHX125
Brand	Bussmann	Bussmann	Bussmann HINODE	HINODE	HINODE

Rated current	125A	150A	180A	230A	300A
Fuse	80ET*2 660GH-80*2	660GH-100*2	660GHX125*2	250FM	315FM
Brand	Bussmann HINODE	HINODE	HINODE	Bussmann	Bussmann

Rated current	380A	450A	580A	720A
Fuse	660GH-400	250FM*2	315FM*2	660GH-400*2
Brand	HINODE	Bussmann	Bussmann	HINODE

Wiring setup examples for Single phase angle, Single-phase zero crossing, and Two-wire three-phase zero crossing

Main circuit wiring diagram

- ※ When electromagnetic switch is used, please install it on the power source side.
- ※ For FS connector wiring, please refer to the right diagram.

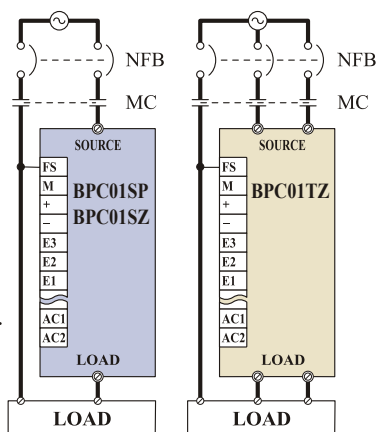

1. Control signal input

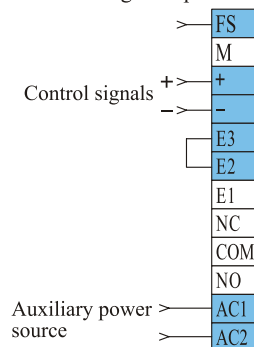

2. Manual control

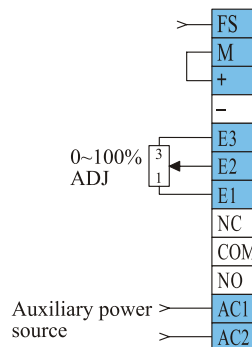

3. Limited adjustment for control signal input, output

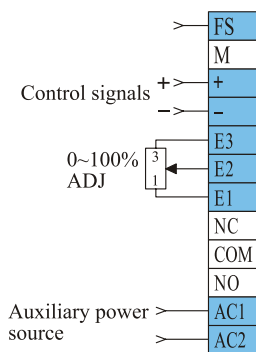

4. Dry contact signal input, outside VR adjustment

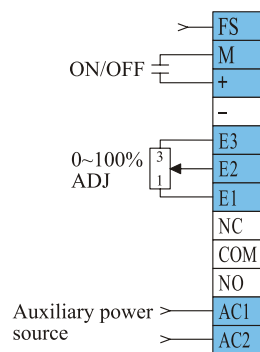

5. Manual-automatic relay switch, outside VR adjustment

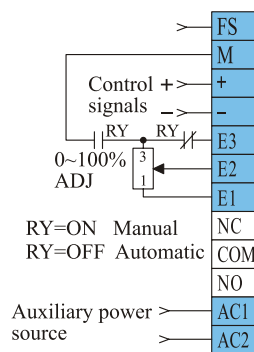

6. Manual-automatic relay switch

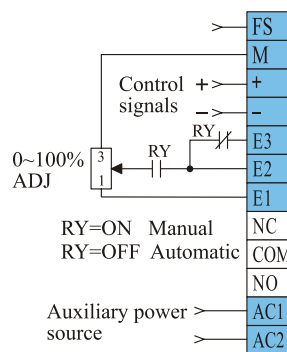

7. Control signal input, basic output setting

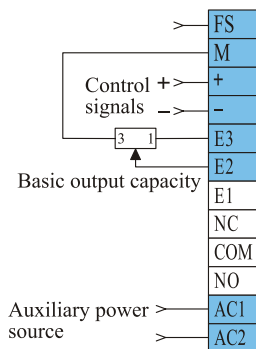

8. Multiple connection, only one for outside VR setting

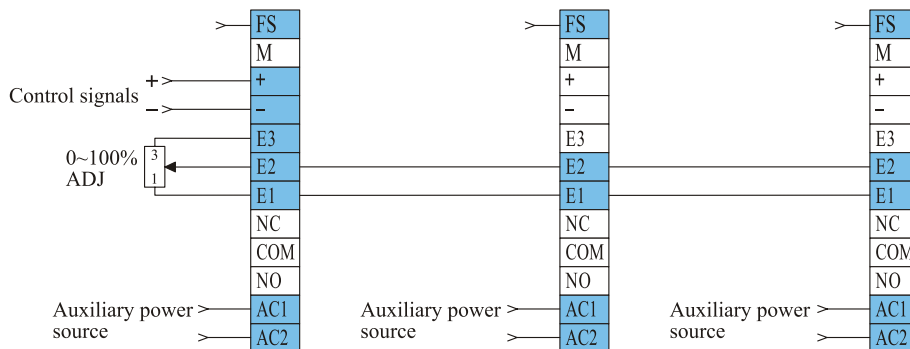

9. Basic and maximum output setting

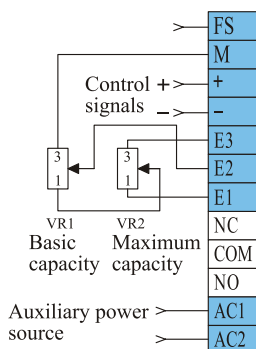

10. Three set connection, independent outside VR setting (limited for 3 sets cascades only)

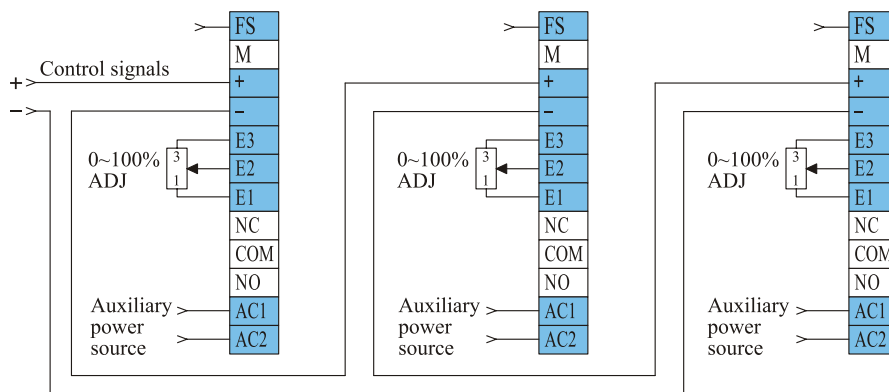

Wiring setup examples for Three-wire three-phase angle, Three-wire three-phase zero crossing and Four-wire three-phase angle

■ Main circuit wiring diagram

※ When electromagnetic switch is used, please install it on the power source side.

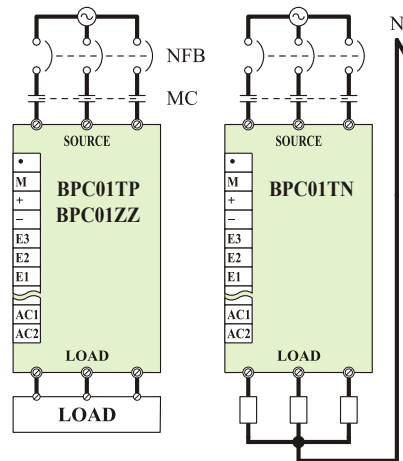

1. Control signal input

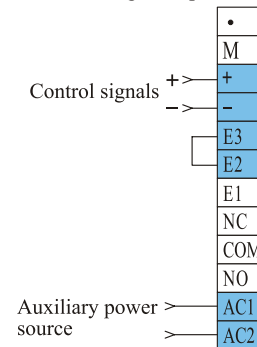

2. Manual control

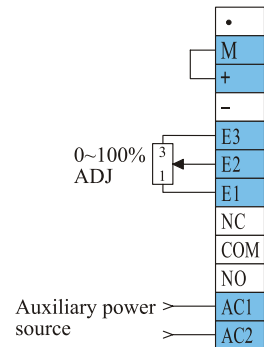

3. Limited adjustment for control signal input, output

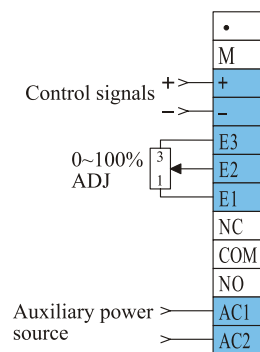

4. Dry contact signal input, outside VR adjustment

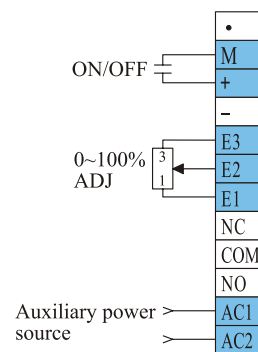

5. Manual-automatic relay switch, outside VR adjustment

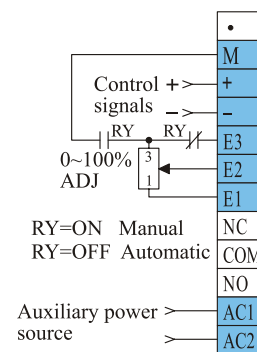

6. Manual-automatic relay switch

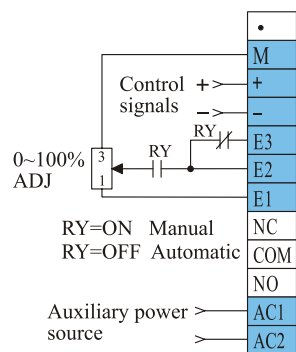

7. Control signal input, basic output setting

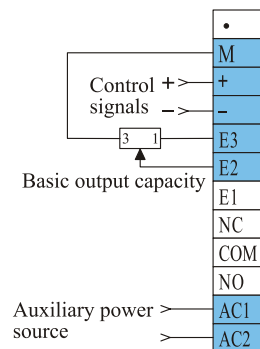

8. Multiple connection, only one for outside VR setting

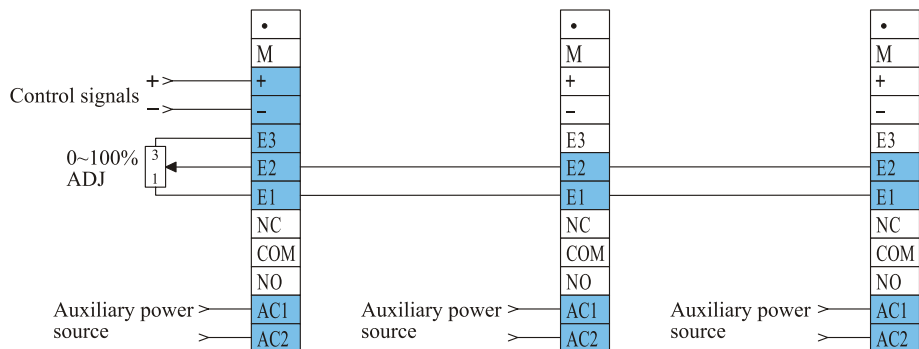

9. Basic and maximum output setting

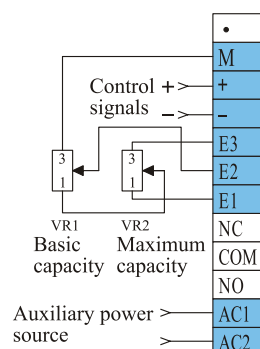

10. Three set connection, independent outside VR setting (limited for 3 sets cascades only)

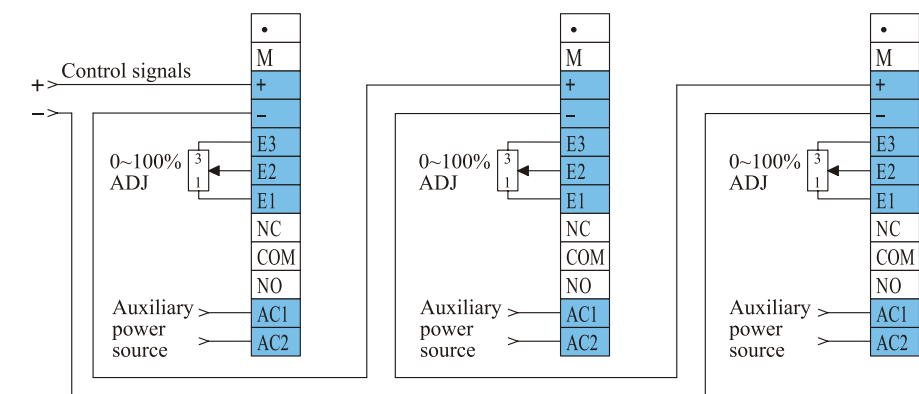

The weights and related dimensions of the power regulators

<i>Single-phase angle and Single-phase zero crossing control (BPC01SP · BPC01SZ)</i>															
Normal rated current	Figure	Outline dimensions (mm)			Net weights (Kg)	Packed dimensions (mm)			Packed weights (Kg)	Fixed-hole dimensions (mm)				Main power source screw	Way of cooling
		Length	Width	Height		Length	Width	Height		L1	L2	L3	W		
30A	A	162	98	133	1.2	225	127	166	1.5	122	○	○	90	M6	Air-cooling
45A	A	200	98	133	1.4	262	127	166	1.7	122	○	○	90	M6	Air-cooling
60,80A	B	162	112	183	1.6	225	140	220	2.0	122	○	○	104	M6	Air-cooling
100A	C	189	112	183	1.9	250	140	220	2.3	122	○	○	104	M6	Fan-cooling
125,150,180A	C	275	112	183	2.9	336	140	220	3.3	122	86	○	104	M8	Fan-cooling
230A	C	287	112	188	3.3	345	140	220	3.7	122	86	○	104	M10	Fan-cooling
300,380A	I	390	140	248	6.2	450	168	277	6.8	122	86	94	132	M10	Fan-cooling
450A	I	390	140	248	7.0	450	168	277	7.6	122	86	94	132	M10*2	Fan-cooling
580A	I	460	140	248	8.6	590	260	390	10.4	122	86	94	132	M10*2	Fan-cooling
720A	I	560	140	248	10.4	690	260	390	12.6	122	86	239	132	M10*2	Fan-cooling

<i>Two-wire three-phase zero crossing control (BPC01TZ)</i>															
Normal rated current	Figure	Outline dimensions (mm)			Net weights (Kg)	Packed dimensions (mm)			Packed weights (Kg)	Fixed-hole dimensions (mm)				Main power source screw	Way of cooling
		Length	Width	Height		Length	Width	Height		L1	L2	L3	W		
30A	A	162	98	133	1.5	225	127	166	1.7	122	○	○	90	M6	Air-cooling
45A	B	162	112	183	1.9	225	140	220	2.2	122	○	○	104	M6	Air-cooling
60,80,100A	C	189	112	183	2.2	250	140	220	2.5	122	○	○	104	M6	Fan-cooling
125A	C	275	112	183	3.1	336	140	220	3.5	122	86	○	104	M8	Fan-cooling
150A	F	326	140	205	4.5	388	168	245	5.0	122	86	○	132	M8	Fan-cooling
180A	F	382	140	205	5.4	443	168	245	5.9	122	86	94	132	M8	Fan-cooling
230A	G	310	155	265	10.3	445	260	410	11.8	230	○	○	143	M10	Fan-cooling
300,380A	G	390	155	265	13.6	525	260	410	15.5	230	80	○	143	M10	Fan-cooling
450A	J	390	260	248	13.0	530	380	390	15.3	122	86	94	252	M10*2	Fan-cooling
580A	J	460	260	248	16.1	590	380	390	18.7	122	86	94	252	M10*2	Fan-cooling
720A	J	560	260	248	20.0	690	380	390	23.0	122	86	239	252	M10*2	Fan-cooling

<i>Three-wire three-phase angle, Three-wire three-phase zero crossing control, Four-wire three-phase angle (BPC01TP · BPC01ZZ · BPC01TN)</i>															
Normal rated current	Figure	Outline dimensions (mm)			Net weights (Kg)	Packed dimensions (mm)			Packed weights (Kg)	Fixed-hole dimensions (mm)				Main power source screw	Way of cooling
		Length	Width	Height		Length	Width	Height		L1	L2	L3	W		
30A	D	200	140	145	2.5	262	168	182	2.8	122	○	○	132	M6	Air-cooling
45A	E	200	140	205	3.0	262	168	245	3.4	122	○	○	132	M6	Air-cooling
60,80,100A	F	202	140	205	3.1	262	168	245	3.5	122	○	○	132	M6	Fan-cooling
125A	F	288	140	205	4.5	350	168	245	5.0	122	86	○	132	M8	Fan-cooling
150A	F	326	140	205	4.9	388	168	245	5.4	122	86	○	132	M8	Fan-cooling
180A	F	382	140	205	5.8	443	168	245	6.3	122	86	94	132	M8	Fan-cooling
230A	H	322	215	265	15.3	445	320	400	17.2	230	○	○	203	M10	Fan-cooling
300,380A	H	402	215	265	20.1	530	320	400	22.3	230	80	○	203	M10	Fan-cooling
450A	K	390	380	248	19.2	515	500	390	22.0	122	86	94	372	M10*2	Fan-cooling
580A	K	460	380	248	24.4	590	500	390	27.4	122	86	94	372	M10*2	Fan-cooling
720A	K	560	380	248	29.5	690	500	390	33.2	122	86	239	372	M10*2	Fan-cooling

Outline appearance and fixed dimensions

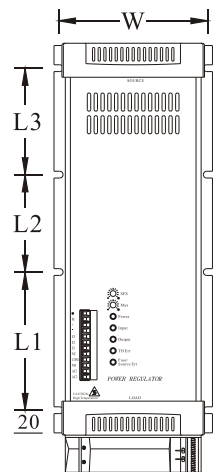
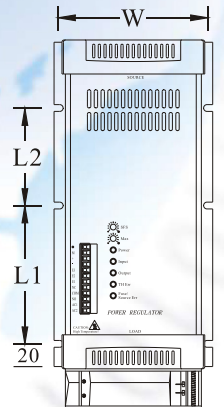
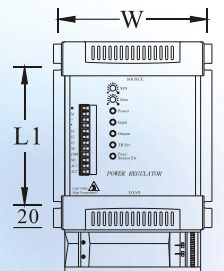
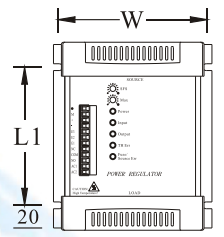

BrainChild

Brainchild Electronic Co., Ltd.

209 Chung Yang Road Nangang Dist. Taipei 11573, Taiwan

Tel: +886-2-2786-1299

Fax: +886-2-2786-1395

sales@brainchild.com.tw

www.brainchildtw.com

2020.01